



Prisma urban plastic drinking fountain made of recycled thermoplastic polymer and stainless steel tap fixing plate.

100% recyclable UV treated material that requires little maintenance. High resistance to impact, wear and inclement weather.

Chrome-plated steel tap with a push-button system (included).

Square urban drinking fountain ideal to be installed in parks, gardens, community areas, schools, streets, etc....

Advantages:

- Vandal-resistant security screws to prevent drinking fountain accessories from being stolen (tap, tap fixing plate, etc...).



Vandal-resistant security screws.

- Not painted. Hardly oxidized. Little maintenance needed.
- Limited flexibility.
- The Tap and tap's fixing plate are interchangeable with other of our drinking fountain models.
- Fixing plate installation by means of metal plugs.

Optional:

- Front or rear opening for possible repairs. It can be customised in stainless steel with a logo or text decoration of the Municipality



Opening can be customised in lacquered or stainless steel.

Vandal-resistant safety screws.



- Customisation with the City Hall logo or coat of arms.



URBAN DRINKING FOUNTAIN

PRISMA



MEASURES:

Width: 145x145 mm.

Visible/ total height: 995 mm.

Bottom plate: 210x210 mm.

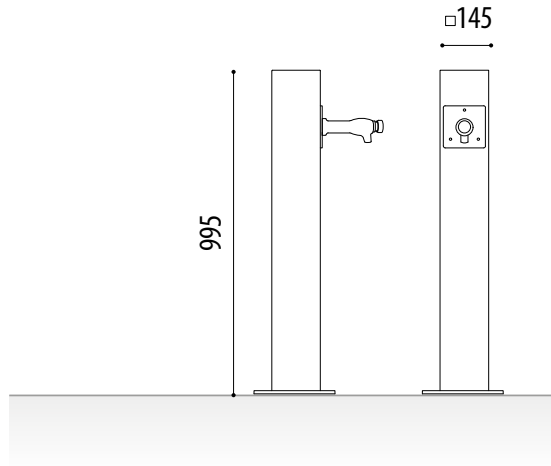

STANDARD FINISHES:

Color black Ref. FPRISMA01

GRATE (OPTIONAL):

Set consisting of two plastic pieces: a channel (lower part) and a grate (top part).



REF. RFP01

NOT INCLUDED:

- Drain grate.
- Fixing plugs.

Ado urban furniture. SL. reserves the right to modify product specifications without prior notice.



 www.adourbanfurniture.com

 +34 93 116 29 75 (International) | +34 93 456 03 03 (Spanish)

 info@adourbanfurniture.com

Office, factory and warehouse: C/ Acer, 37-43 Pol. Ind. Les Guixeres 08915 Badalona - Spain