



Nevada dog drinking fountain in recycled thermoplastic polymer. Chrome-plated steel upper tap for drinker filling by means of a push-button system (included).

100% recyclable UV treated material that requires little maintenance.

High resistance to impact, wear and inclement weather.

Stainless steel drinker for animal use, with hole in the central part to avoid stagnant water and with side lever to tilt the drinker for later emptying

Advantatges:

- Vandal-resistant security screws to prevent drinking fountain accessories from being stolen (tap, tap fixing plate, etc...).

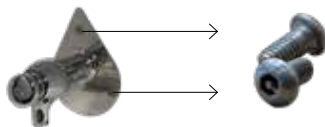

Vandal-resistant security screws

- Not painted. Hardly oxidized. Little maintenance needed.
- Limited flexibility.
- The Tap and tap's fixing plate are interchangeable with other of our drinking fountain models. Drinking fountains.
- Fixing plate installation by means of metal plugs.

Optional:

- Front or rear opening for possible repairs. Customisable in stainless steel with a logo or text decoration of the City Hall.

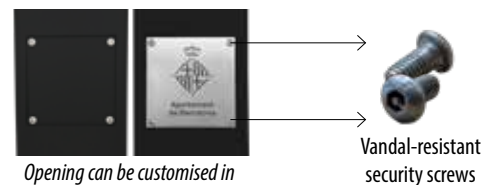

- Customisation with the City Hall logo or coat of arms.





URBAN DRINKING FOUNTAIN

NEVADA



MEASURES:

Width: 145x145 mm.
Visible / total height: 995 mm.
Bottom plate: 210x210 mm.

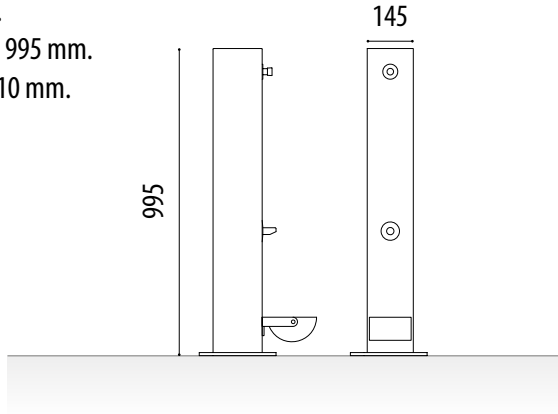

STANDARD FINISHES:

Color blackRef. FDR0P01

GRATE (OPTIONAL):

Set consisting of two plastic pieces: a channel (lower part) and a grate (top part).



REF. RFP01

NOT INCLUDED:

- Drain grate.
- Fixing plugs.

Ado urban furniture. SL. reserves the right to modify product specifications without prior notice.



 www.adourbanfurniture.com

 +34 93 116 29 75 (International) | +34 93 456 03 03 (Spanish)

 info@adourbanfurniture.com

Office, factory and warehouse: C/ Acer, 37-43 Pol. Ind. Les Guixeres 08915 Badalona - Spain