



Recycled Material



Optional front opening in stainless steel with personal logo

**Fox urban plastic drinking fountains** made of recycled thermoplastic polymer with independent push-button chrome-plated steel taps (people and animal use). Stainless steel drinker for animal use, with hole in the central part to avoid stagnant water and with side lever to tilt the drinker for later emptying.

100% recyclable UV treated material that requires little maintenance.

High resistance to impact, wear and inclement weather.

Square urban drinking fountain ideal to be installed in parks, gardens, community areas, schools, streets, etc....

### Advantages:

- Vandal-resistant security screws to prevent drinking fountain accessories from being stolen (tap, tap fixing plate, etc...).

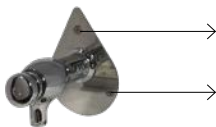

Vandal-resistant security screws

- Not painted. Hardly oxidized. Little maintenance needed.
- Limited flexibility.
- The Tap and tap's fixing plate are interchangeable with other of our drinking fountain models.
- Fixing plate installation by means of metal plugs.

### Optional:

- Front or rear opening for possible repairs. Customisable in stainless steel with a logo or text decoration of the City Hall.



Opening can be customised in lacquered or stainless steel.



Vandal-resistant security screws.

- Customisation with the City Hall logo or coat of arms





# URBAN DRINKING FOUNTAIN

## FOX



### MEASURES:

Width: 145x145 mm.

Visible / total height: 995 mm.

Bottom plate: 210x210 mm.

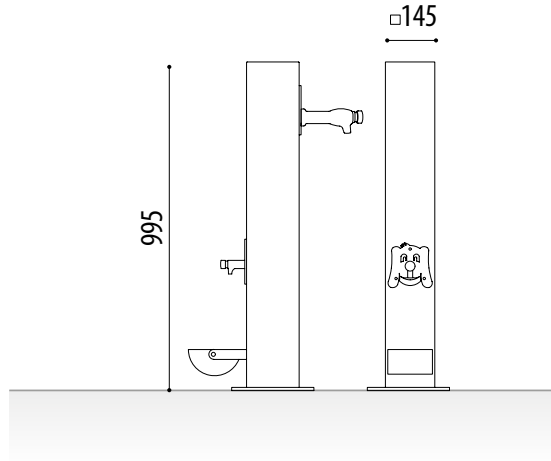

### STANDARD FINISHES:

Color black ..... Ref. FFOX01

### GRATE (OPTIONAL):

Set consisting of two plastic pieces: a channel (lower part) and a grate (top part).



REF. RFP01

### NOT INCLUDED:

- Drain grate.
- Fixing plugs.

Ado urban furniture. SL. reserves the right to modify product specifications without prior notice.



 [www.adourbanfurniture.com](http://www.adourbanfurniture.com)

 +34 93 116 29 75 (International) | +34 93 456 03 03 (Spanish)

 [info@adourbanfurniture.com](mailto:info@adourbanfurniture.com)

Office, factory and warehouse: C/ Acer, 37-43 Pol. Ind. Les Guixeres 08915 Badalona - Spain